

CEILING-MOUNT SERIES

Self-Contained Air- and Water-Cooled Units



MOVINCOOL®
THE #1 SPOT COOLING SOLUTION



CM SERIES

Breakthrough High-capacity Cooling for Computer Rooms and Offices

The latest addition to the award-winning MovinCool line of spot coolers is the CM Series of ceiling-mount packaged air conditioners, including the air-cooled CM12 and CM25 models, as well as the new CMW30 water-cooled model.

Featuring the lowest top-to-bottom profile in the industry, the CM Series fits into virtually any drop ceiling, making it the perfect cooling solution for server rooms, which have limited floor space.

"The health-care center has no more shut-downs due to overheating. The CM12 is perfectly designed for this type of application. It has the usual MovinCool quality, it's easy to install in tight spaces, and it has an affordable price tag."

Joe Dotson, Service Account Manager
Scarborough Medical Services, Inc.

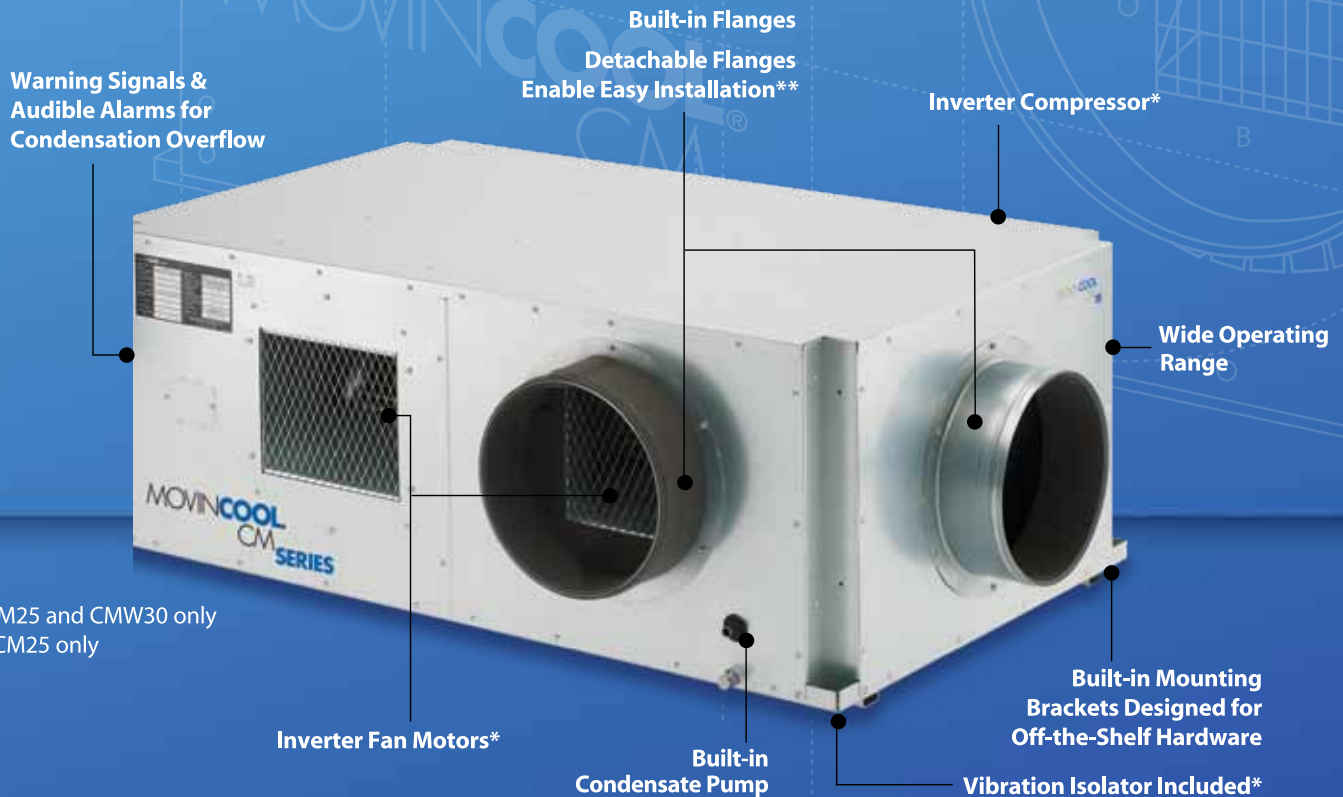

*CM25 and CMW30 only
**CM25 only

CM12 KEY FEATURES

- 10,500 Btu/h at 80°F 50% RH (Evaporator)
95°F 50% RH (Condenser)
- 13,000 Btu/h at 95°F 60% RH
- 115V, 15 amps – no special electric required
- No floor space needed
- Can fit into tight ceiling spaces
- Compact, self-contained unit is easy to install
- Environmentally friendly design – R-410A refrigerant and RoHS compliant

CM25 KEY FEATURES

- 25,000 Btu/h at 80°F 50% RH (Evaporator)
95°F 50% RH (Condenser)
- High sensible cooling at 18,900 Btu/h
- Environmentally-friendly design – 14 SEER, variable-speed compressor, R-410A refrigerant and RoHS compliant
- Compact, self-contained unit is easy to install
- Wall mount controller offers advanced programmability and settings

CMW30 KEY FEATURES

- 29,400 Btu/h total cooling capacity
- 22,000 Btu/h sensible cooling for computer rooms
- Wide condenser EWT range – 45°F to 115°F
- Environmentally-friendly design – 17 IEER, variable-speed compressor, R-410A refrigerant and RoHS compliant
- Compact, self-contained unit is easy to install
- Wall mount controller offers advanced programmability and settings

Application

"For an office, especially on a corner with windows facing the sun and equipment which give off heat, the MovinCool CM25 is definitely the way to go."

Nick Best, Director, Cam Op & Editor
New Creation Video Productions

"The flexibility of the CM25's control options made it very easy for us to integrate the unit into our automation system. It allows us to remotely monitor, schedule, trend and alarm the points we want, so we have greater control over the unit."

Matt Steding, Division Maintenance Manager
Allina Hospitals and Clinics

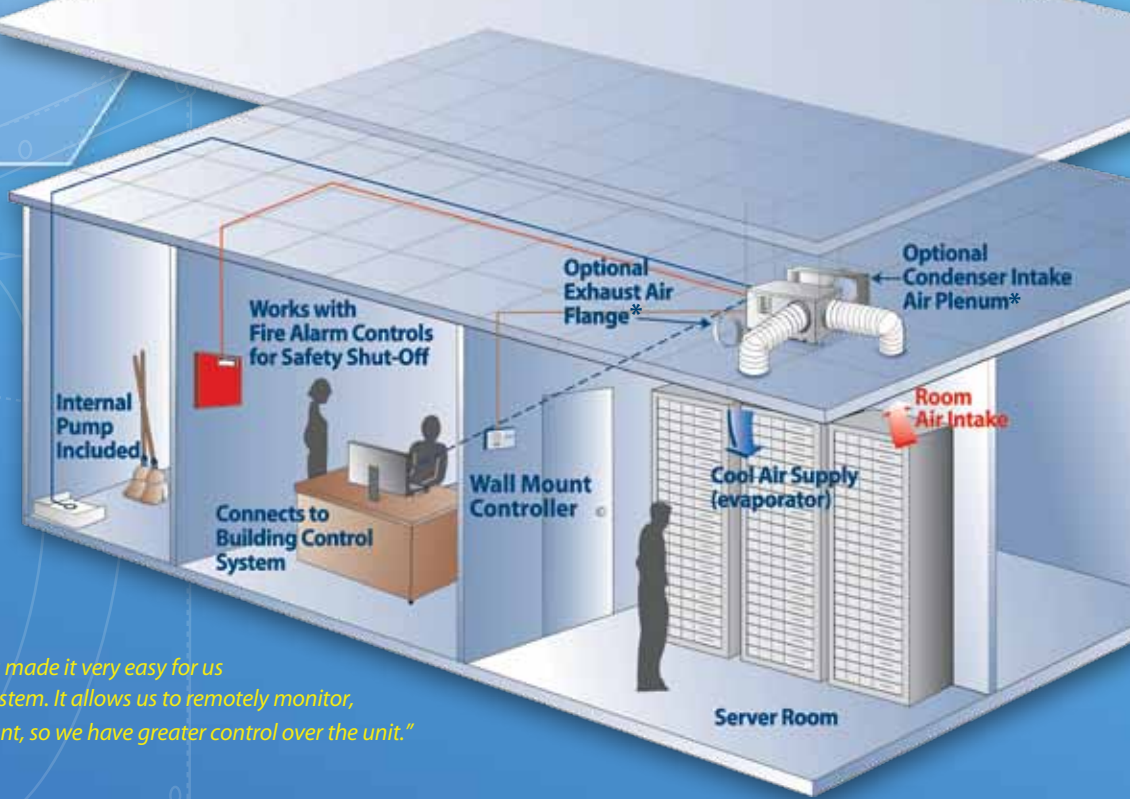

*N/A for CMW30 model

Accessories



CONDENSER AIR REMOVAL

If removing the exhaust is needed, MovinCool makes it easy. The flange can be used to attach a 10-inch (CM12) or 12-inch (CM25) diameter duct for more air exhaust options (duct not included).

#	PART NAME	CM12	CM25	CMW30
1	Exhaust Air Flange	481170-0440	481170-0191	N/A



CONDENSER AIR INTAKE

The air plenum can be used to prevent negative air pressure in the ceiling space when using the exhaust air-flange and duct to remove exhaust from the ceiling space. Simply attach a 10-inch (CM12) or 14-inch (CM25) diameter duct to the air plenum to bring in air from outside of the ceiling space (duct not included).

#	PART NAME	CM12	CM25	CMW30
2	Condenser Intake Air Plenum	481769-0220	481769-0240	N/A
2A	Condenser Filter Kit (not shown)	N/A	484409-0130	N/A



WALL THERMOSTAT

Weekday & weekend programmable digital millivolt thermostat.

#	PART NAME	CM12	CM25	CMW30
3	Wall Thermostat	LA484500-3430	Included*	Included*



AUTO CONDENSATE REMOVAL

Condensate pump with 4-foot lift capacity is included with all the units. If more than 4-foot lift capacity is needed, simply use this optional condensate pump kit to boost lift capacity to 17-feet.

#	PART NAME	CM12	CM25	CMW30
4	Condensate Pump Kit	N/A	GX484789-0180	GX484789-0190

*Wall Mounted Controller with LCD Display

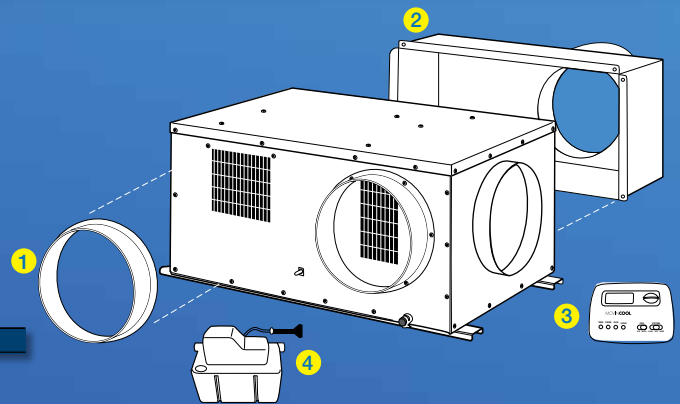

INDIVIDUAL PART DESCRIPTIONS MOVINCOOL CM12, CM25 and CMW30

1 Exhaust Air Flange	10" or 12" diameter gray metal flange with mounting screws.
2 Condenser Intake Air Plenum	Gray metal plenum with 10" or 14" diameter return air flange. Includes mounting screws.
2A Condenser Filter Kit (not shown)	Optional filter kit for condenser air intake for use in heavily dusty environments.
3 Wall Thermostat	Weekday & weekend programmable digital millivolt thermostat.
4 Condensate Pump Kit	230V pump kit to boost lift capacity to 17-feet. Includes installation hardware.

CM Series Specifications

MOVINCOOL
THE #1 SPOT COOLING SOLUTION



Water Cooled

MOVINCOOL TECHNICAL SPECIFICATIONS		CM12	CM25 ¹	CMW30 ²
Electronic Features	Operation	Millivolt Thermostat (Not Included)	Wall Mounted Controller	Wall Mounted Controller
	Control	Electronic	Electronic	Electronic
Electrical Characteristics	Voltage Requirement	115V, 1 Phase, 60 Hz	208/230V, 1 Phase, 60 Hz	208/230V, 1 Phase, 60 Hz
	Min. - Max. Voltage	105-125	198-250	198-250
	Recommended Fuse Size	15 amps	20 amps	20 amps
Cooling Capacity and Power Consumption				
Evaporator: 80 °F, 50% RH	Total Cooling Capacity	10,500 Btu/h ₁	25,000 Btu/h ₂	29,400 Btu/h ₂
	Condenser: 95 °F, 50% RH Sensible Cooling Capacity	7,200 Btu/h ₁	18,000 Btu/h ₂	20,800 Btu/h ₂
Water-cooled model: EWT/LWT: 85 °F/ 95 °F	Power Consumption	1.23 kW ₁	2.90 kW ₂	1.99 kW ₂
	Current Consumption	11.2 amps ₁	12.6 amps ₂	8.9 amps ₂
Evaporator: 72 °F, 50% RH	Total Cooling Capacity	9,200 Btu/h ₁	25,000 Btu/h ₂	25,200 Btu/h ₂
	Condenser: 95 °F, 50% RH Sensible Cooling Capacity	7,000 Btu/h ₁	18,900 Btu/h ₂	22,000 Btu/h ₂
Water-cooled model: EWT/LWT: 85 °F/ 95 °F	Power Consumption	1.23 kW ₁	3.20 kW ₂	2.00 kW ₂
	Current Consumption	11 amps ₁	15 amps ₂	9 amps ₂
Evaporator	Fan Type	Centrifugal	Centrifugal	Centrifugal
	Max. Air Flow - high/low	324/228 CFM ₁	950/800 CFM ₂	1060/840 CFM ₂
	Max. External Static Pressure	0.16 IWG	0.60 IWG	0.66 IWG
Condenser	Fan Type	Centrifugal	Centrifugal	Water Cooled Condenser
	Max. Air Flow - high/low	700/370 CFM	1,600/1,300 CFM	N/A
	Max. External Static Pressure	0.12 IWG	0.50 IWG	N/A
Compressor	Type	Hermetic Rotary	Hermetic Swing Inverter	Hermetic Swing Inverter
Refrigerant	Type	R-410A	R-410A	R-410A
Dimensions	W x D x H (without flange)	32 x 20 x 15.2 in	53 x 32 x 20 in	45 x 32 x 20 in
	W x D x H (with flange)	35 x 23 x 16 in	57 x 36 x 20 in	49 x 35 x 20 in
Net Weight/Shipping Weight		123/137 lbs	310/353 lbs	236/271 lbs
Condensate Pump Capacity (Internal pump included)	Pump Rate	5 gal/h	5 gal/h	5 gal/h
	Head	4 ft	4 ft	4 ft
Operating Conditions	Evaporator	65° – 95°F, 50% RH	60°F - 95°F, 50% RH	55°F - 95°F, 50% RH
	Condenser	65° – 113° F	50°F - 113°F	45°F - 115°F (Condenser Water)
Max. Duct Length	Cold Duct Hose	20 ft ₃	120 ft ₃	120 ft ₃
	Hot Duct Hose	10 ft ₃	90 ft ₃	N/A
Max. Sound Level	Under ceiling tile with evaporator duct	52 dB(A)	55 dB(A)	55 dB(A)

¹ Measured with two 6 ft ducts with one 90° bend each, supply grill and return grill with filter (0.16 IWG external static pressure) (ducts not included)

² Measured with two 20 ft ducts with one 90° bend each, supply grill and return grill with filter (0.30 IWG external static pressure) (ducts not included)

³ Confirm pressure drop of duct, grills and filter with manufacturer specifications.

*Specification information shown with 230V

All specifications subject to change without notice. Standard warranty includes 12 months on entire unit and 36 months on the compressor. Visit www.movincool.com/reg for details on MovinCool's industry-best free Extended Warranty Program which includes both parts and labor on units. All models feature compressor overload relay and fan motor protection. All models also feature compressor short-cycle protection, return air thermostat, automatic restart and built-in condensate pump. Only the CM12 is 50 Hertz (Hz) compatible with a slight performance decrease from specifications listed above.

For more information visit www.movincool.com



800-264-9573

www.movincool.com

DENSO SALES CALIFORNIA, INC.

3900 Via Oro Ave

Long Beach, CA 90810

360-0811-CMS

D1522.334